

**INDEX**

**1 . WARNINGS ..... 3**

**2 . TECHNICAL SPECIFICATIONS..... 3**

**3 . LAYOUT AND COMPONENTS OF 624 BLD ..... 3**

**3.1 Description of components..... 3**

**4 . ELECTRICAL CONNECTIONS..... 4**

**4.1 Connection of photocells and safety devices ..... 4**

**4.2 J1 Terminal-board - Accessories (Fig.2) ..... 5**

**4.3 J2 Terminal-board - motor - flashing light and fan (Fig.2)..... 5**

**4.4 J8 Connector - Motor capacitor (Fig.2) ..... 5**

**4.5 J9 Terminal-board - Power supply (Fig.2)..... 5**

**4.6 J3, J5 Rapid connectors - for opening and closing limit-switches (Fig.2)..... 5**

**4.7 J6 Connector - Beam breaking sensor (Fig. 2)..... 6**

**4.8 J11a,b,c Connector - Quick-fit connector for external loop detector (Fig.2) ..... 6**

**4.9 J4 Quick fit Connector - for Minidec, Decoder and RP ..... 6**

**5 . PROGRAMMING ..... 6**

**5.1 1ST LEVEL PROGRAMMING ..... 6**

**5.2 2nd LEVEL PROGRAMMING ..... 7**

**5.3 3rd LEVEL PROGRAMMING ..... 8**

**5.4 MODIFICATION OF FUNCTION LOGIC ..... 9**

**5.5 MODIFICATION OF PRE-SETTING OF LOGICAL PARAMETERS..... 10**

**6 . START-UP ..... 10**

**6.1 LEDS CHECK ..... 10**

**7 . AUTOMATED SYSTEM TEST ..... 10**

**8 . MASTER-SLAVE ..... 11**

**9 . FUNCTION LOGICS TABLES ..... 12**

**ENGLISH**

## EC DECLARATION OF CONFORMITY

**Manufacturer:** FAAC S.p.A.  
**Address:** Via Benini, 1 - 40069 Zola Predosa BOLOGNA - ITALY  
**Declares that:** 624BLD control board

- conforms to the essential safety requirements of the following directives:

73/23/EEC and subsequent amendment 93/68/EEC.  
 89/336/EEC and subsequent amendment 92/31/EEC and 93/68/EEC

Additional note:

This product underwent tests in a typical uniform configuration  
 (all products manufactured by FAAC S.p.A.).

Bologna, 01 January 2006

The Managing Director

A. Bassi  

## WARNINGS FOR THE INSTALLER

### GENERAL SAFETY OBLIGATIONS

- ATTENTION! To ensure the safety of people, it is important that you read all the following instructions. Incorrect installation or incorrect use of the product could cause serious harm to people.**
- Carefully read the instructions before beginning to install the product.
- Do not leave packing materials (plastic, polystyrene, etc.) within reach of children as such materials are potential sources of danger.
- Store these instructions for future reference.
- This product was designed and built strictly for the use indicated in this documentation. Any other use, not expressly indicated here, could compromise the good condition/operation of the product and/or be a source of danger.
- FAAC declines all liability caused by improper use or use other than that for which the automated system was intended.
- Do not install the equipment in an explosive atmosphere: the presence of inflammable gas or fumes is a serious danger to safety.
- The mechanical parts must conform to the provisions of Standards EN 12604 and EN 12605.  
For non-EU countries, to obtain an adequate level of safety, the Standards mentioned above must be observed, in addition to national legal regulations.
- FAAC is not responsible for failure to observe Good Technique in the construction of the closing elements to be motorised, or for any deformation that may occur during use.
- The installation must conform to Standards EN 12453 and EN 12445.  
For non-EU countries, to obtain an adequate level of safety, the Standards mentioned above must be observed, in addition to national legal regulations.
- Before attempting any job on the system, cut out electrical power.
- The mains power supply of the automated system must be fitted with an all-pole switch with contact opening distance of 3mm or greater. Use of a 6A thermal breaker with all-pole circuit break is recommended.
- Make sure that a differential switch with threshold of 0.03 A is fitted upstream of the system.
- Make sure that the earthing system is perfectly constructed, and connect metal parts of the means of the closure to it.
- The safety devices (EN 12978 standard) protect any danger areas against **mechanical movement Risks**, such as crushing, dragging, and shearing.
- Use of at least one indicator-light (e.g. FAACLIGHT) is recommended for every system, as well as a warning sign adequately secured to the frame structure, in addition to the devices mentioned at point "15".
- FAAC declines all liability as concerns safety and efficient operation of the automated system, if system components not produced by FAAC are used.
- For maintenance, strictly use original parts by FAAC.
- Do not in any way modify the components of the automated system.
- The installer shall supply all information concerning manual operation of the system in case of an emergency, and shall hand over to the user the warnings handbook supplied with the product.
- Do not allow children or adults to stay near the product while it is operating.
- Keep radio controls or other pulse generators away from children, to prevent the automated system from being activated involuntarily.
- Transit is permitted only when the automated system is idle.
- The user must not attempt any kind of repair or direct action whatever and contact qualified personnel only.
- Maintenance: check at least every 6 months the efficiency of the system, particularly the efficiency of the safety devices (including, where foreseen, the operator thrust force) and of the release devices.
- Anything not expressly specified in these instructions is not permitted.**

# CONTROL UNIT 624 BLD

## 1. WARNINGS

- Attention:** Before attempting any work on the control unit (connections, maintenance), always turn off power.
- Install, upstream of the system, a differential thermal breaker with adequate tripping threshold.
  - Connect the earth cable to the terminal on the J9 connector of the unit (see fig.2).
  - Always separate power cables from control and safety cables (push-button, receiver, photocells, etc.). To avoid any electrical noise, use separate sheaths or a screened cable (with the screen earthed).

## 2. TECHNICAL SPECIFICATIONS

Power supply voltage	230 Vac (+6% -10%) - 50 Hz
Absorbed power	7 W
Motor max. load	300 W
Power supply for accessories	24 Vdc
Accessories max. current	500 mA
Operating ambient temperature	-20°C - +55°C
Fuses	F1 = F 5A - 250V F2 = T 0.8A - 250V
Function logics	Automatic, Automatic 1, Semiautomatic, Parking, Parking-Automatic, Condo, Condo-automatic, FAAC-CITY, Dead-man, Remote, Custom
Work time	Programmable (from 0 to 4 minutes)
Pause time	Programmable (from 0 to 4 minutes)
Motor power	Programmable on 50 levels
Terminal board inputs	Loop1, Loop2, Open, Close, Closing safety devices, Stop, Emergency, Power supply 230Vac + Earth
Connector inputs	Opening and closing limit-switch, Detector Motor capacitor, Beam detachment sensor
Terminal board outputs	Flashing light, Fan, Motor, Power supply 24 Vdc, Fail-safe, Status output, Indicator light 24 Vdc, BUS
Rapid connector	5-pin Minidec board coupling, Decoder, Receiver RP/RP2
Programming	No. 3 keys (+, -, F) and display
Programmable functions	Logics, Pause Time, Power, Loop 1 and 2, Thrust torque, Pre-flashing, Slow closure, Deceleration time, Work time, Indicator light output, Fail-safe output, Status output, BUS output, Assistance request

## 3. LAYOUT AND COMPONENTS OF 624 BLD

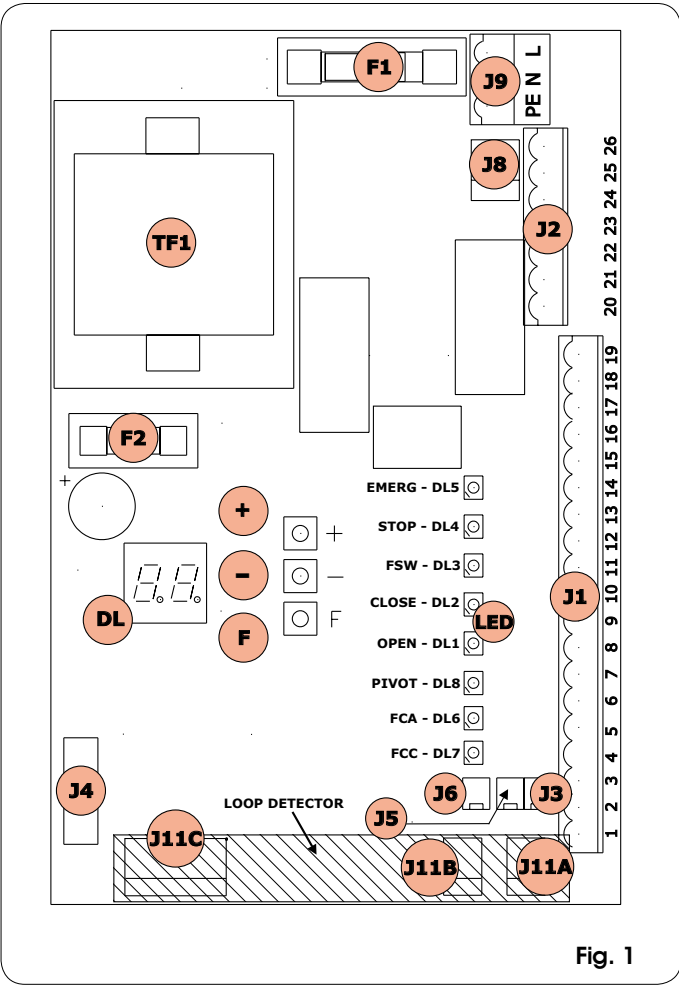

Fig. 1

### 3.1 DESCRIPTION OF COMPONENTS

<b>DL</b>	SIGNALS AND PROGRAMMING DISPLAY
<b>LED</b>	INPUT STATUS CONTROL LEDs
<b>J1</b>	LOW-VOLTAGE TERMINAL BOARD
<b>J2</b>	TERMINAL BOARD FOR CONNECTION OF MOTOR, FLASHING LIGHT AND FAN
<b>J3</b>	OPENING LIMIT-SWITCH CONNECTOR
<b>J4</b>	CONNECTOR: DECODER MINIDEC / RP RECEIVER
<b>J5</b>	CLOSING LIMIT-SWITCH CONNECTOR
<b>J6</b>	CONNECTOR FOR ROD BREAKING SENSOR
<b>J8</b>	CONNECTOR FOR MOTOR THRUST CAPACITOR
<b>J9</b>	TERMINAL-BOARD FOR 230 VAC POWER SUPPLY
<b>J11</b>	CONNECTOR FOR EXTERNAL LOOP DETECTOR
<b>F1</b>	FUSE FOR MOTORS AND TRANSFORMER PRIMARY WINDING (F 5A)
<b>F2</b>	FUSE FOR LOW VOLTAGE AND ACCESSORIES (T 800mA)
<b>F</b>	PROGRAMMING PUSH-BUTTON "F"
<b>+</b>	PROGRAMMING PUSH-BUTTON "+"
<b>-</b>	PROGRAMMING PUSH-BUTTON "-"
<b>TF1</b>	TRANSFORMER

ENGLISH

4. ELECTRICAL CONNECTIONS

ENGLISH

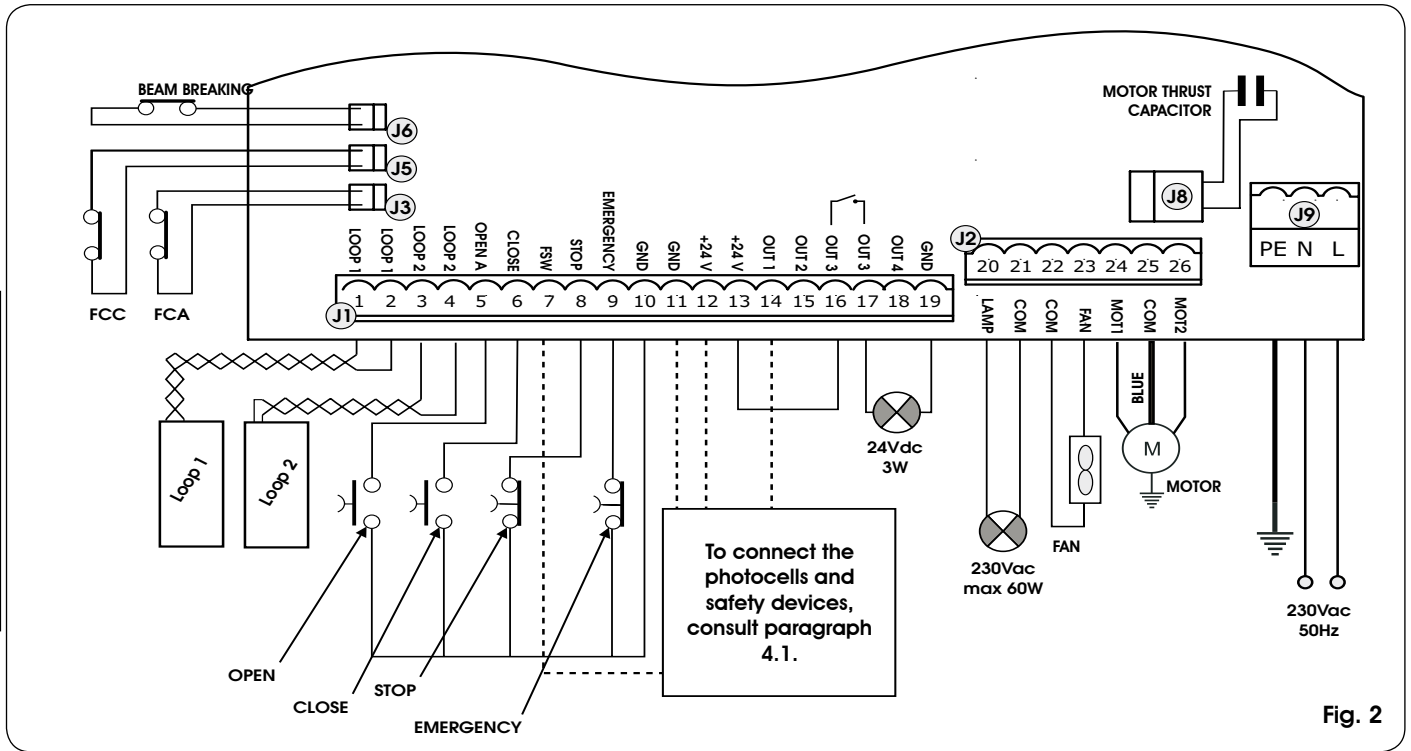

Fig. 2

4.1 CONNECTION OF PHOTOCELLS AND SAFETY DEVICES

Before you connect the photocells (or other devices) we advise you to select the type of operation according to the movement zone they have to protect.

**Closing safety devices:** they are tripped only during the barrier closing movement, and, therefore, are suitable for protecting the closing zone against the risk of impact.

**!** If two or more safety devices (NC contacts) have to be connected, put them in series with each other (see fig.3).

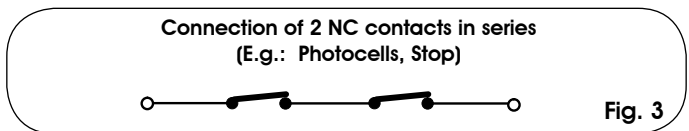

Fig. 3

**!** If two or more safety devices with N.O. contacts have to be connected, put them in parallel with each other (see fig.4).

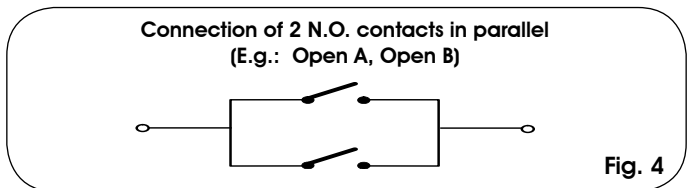

Fig. 4

Connection of 1 pair of closure photocells with FAIL SAFE facility.

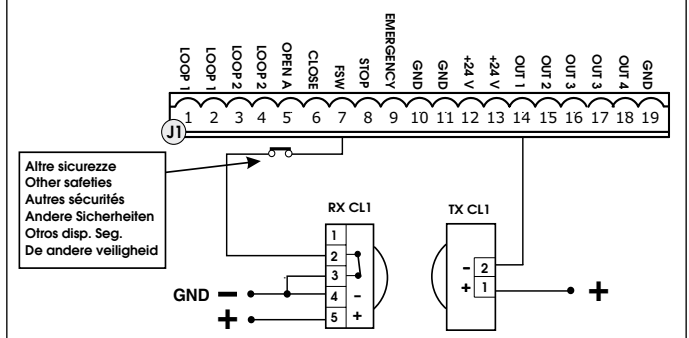

Fig. 5

Connection of two pairs of closure photocells

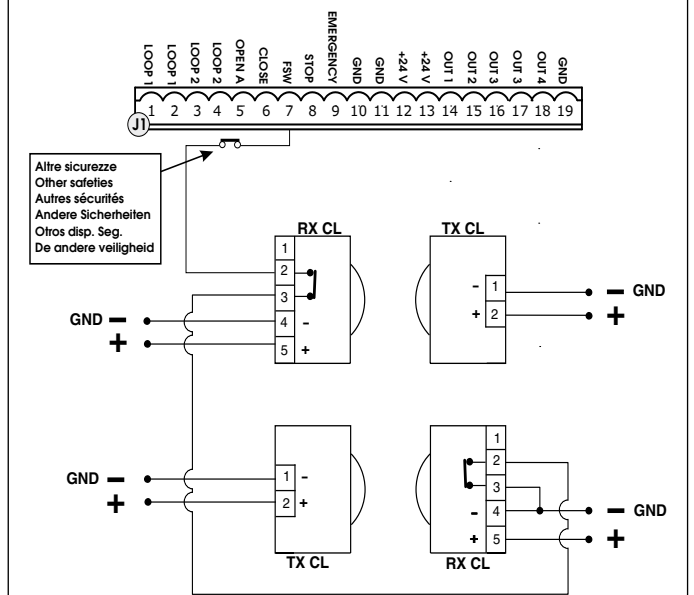

Fig. 6a

Connection of 1 pair of closure photocells

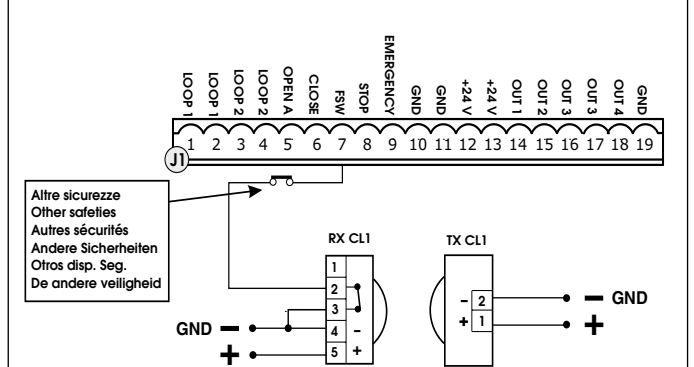

Fig. 6b

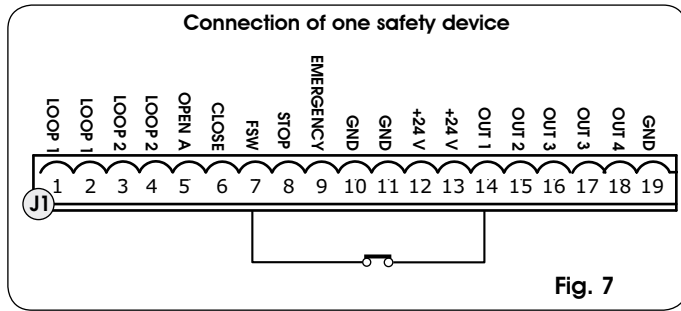

Fig. 7

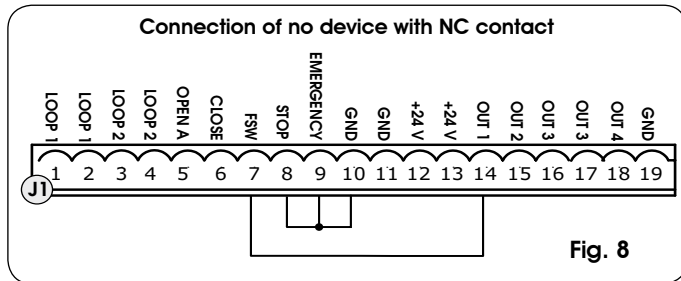

Fig. 8

**4.2. J1 TERMINAL-BOARD - ACCESSORIES (FIG.2)**

**LOOP 1 - Power supply to loop1 (OPEN - terminals 1-2):** use these terminals to connect the loop you wish to use as an OPEN pulse generator.

**LOOP 2 - Power supply to loop2 (SAFETY/CLOSE - terminals 3-4):** connect between these terminals the loop you wish to use as a SAFETY/CLOSE pulse generator.

**OPEN - "Opening" Command (N.O. - terminal 5):** this refers to any pulse generator (e.g.: push-button) which, by closing a contact, commands the barrier to open and/or close.

*To install several total opening pulse generators, connect the N.O. contacts in parallel (see fig. 4).*

**CLOSE - "Closing" Command (N.O. - terminal 6):** this refers to any pulse generator (e.g.: push-button) which, by closing a contact, commands the barrier to close.

*To install several total opening pulse generators, connect the N.O. contacts in parallel (see fig. 4).*

**FSW - Closing safety-devices contact (N.C. - terminal 7)** The purpose of the closing safety devices is to protect the barrier movement area during closure, by reversing motion. They are never tripped during the opening cycle. If the **closing safety devices** are engaged when the automated system is in open status, they prevent the closing movement.

*To install several closing safety devices, connect the N.C. contacts in series (fig. 3).*

**If closing safety devices are not connected, jumper connect the FSW and OUT1 terminals (fig. 8).**

**STOP - STOP contact (N.C. - terminal 8):** this refers to any device (e.g.: push-button ) which, by opening a contact, can stop the motion of the automated system.

*To install several STOP devices, connect the N.C. contacts in series (fig. 3).*

**If stop safety devices are not connected, jumper connect the STOP and GND terminals (fig. 8).**

**EMERGENCY - EMERGENCY contact (N.C. - terminal 9)** this refers to any switch which, by being activated in emergency state, opens the barrier and stops its movement until the contact is restored.

**If emergency safety devices are not connected, jumper connect the EMERGENCY and GND terminals (fig. 8).**

**GND\_ (terminals 10-11-19) - Negative contact for feeding accessories**

**24 Vdc (terminals 12-13) - Positive contact for feeding accessories**



**Max. load of accessories: 500 mA. To calculate absorption values, refer to the instructions for individual accessories.**

**OUT 1 - Outout 1 (terminal 14):**The output can be set in one of the functions described in 2nd level programming (see par.5.2.). Default value is FAILSAFE.

Maximum applicable load: 24 Vdc with 100 mA.

**OUT 2 - Output 2 (terminal 15):** The output can be set in one of the functions described in 2nd level programming (see par.5.2.). Default value is CLOSED beam.

Maximum applicable load: 24 Vdc with 100 mA.

**OUT 3 - Output 3 (terminal 16-17):** The output can be set in one of the functions described in 2nd level programming (see par.5.2.). Default value is INDICATOR LIGHT.

Connect a 24 Vdc - 3 W max. indicator light, if any, to these terminals, following the instructions in fig. 2.

Maximum applicable load: 24 Vdc or Vac with 500 mA.



**To avoid endangering correct operation of the system, do not exceed the indicated power.**

**OUT 4 - Output 4 (terminal 18):** The output can be set in one of the functions described in 2nd level programming (see par.5.2.). Default value is BEAM LIGHTING.

Maximum applicable load: 24 Vdc with 100 mA.

**4.3. J2 TERMINAL-BOARD - MOTOR - FLASHING LIGHT AND FAN (FIG.2)**

**M (COM-MOT1-MOT2):** Motor connection

**LAMP (LAMP-COM):** Flashing light output ( 230 V ~)

**FAN (FAN-COM):** Fan output ( 230 V ~)

**4.4. J8 CONNECTOR - MOTOR CAPACITOR (FIG.2)**

Rapid connector for connecting the motor thrust capacitor.

**4.5. J9 TERMINAL-BOARD - POWER SUPPLY (FIG.2)**

**PE :** Earth connection

**N :** Power supply 230 V~ ( Neutral )

**L :** Power supply 230 V~ ( Line )



**To ensure correct operation, the board must be connected to the earth conductor in the system. Install an adequate differential thermal breaker upstream of the system.**

**4.6. J3, J5 RAPID CONNECTORS - FOR OPENING AND CLOSING LIMIT-SWITCHES (FIG.2)**

Quick-fit connector for connection of the opening (J3) and closing (J5) limit-switches.

**4.7 J6 CONNECTOR - BEAM BREAKING SENSOR (FIG. 2)**

Quick-fit connector for connecting the beam breaking sensor (where present). If this sensor is absent, leave the supplied jumper in place.

**4.8. J11A,B,C CONNECTOR - QUICK-FIT CONNECTOR FOR EXTERNAL LOOP DETECTOR (FIG.2)**

Quick-fit connector for connecting the external loop-detector. For adjustment and programming consult the relevant instruction.

**4.9 J4 QUICK FIT CONNECTOR - FOR MINIDEC, DECODER AND RP**

It is used for rapid connection of Minidec, Decoder and RP/RP2 Receivers.

If you are using an RP2 twin-channel receiver, you will be able to directly command the automated system's OPEN and CLOSE from a twin-channel radio control.

If using a single-channel RP type receiver, only OPEN can be commanded.

Fit the accessory with the components side directed toward the board interior.

 **Insert and remove the boards ONLY after cutting power.**

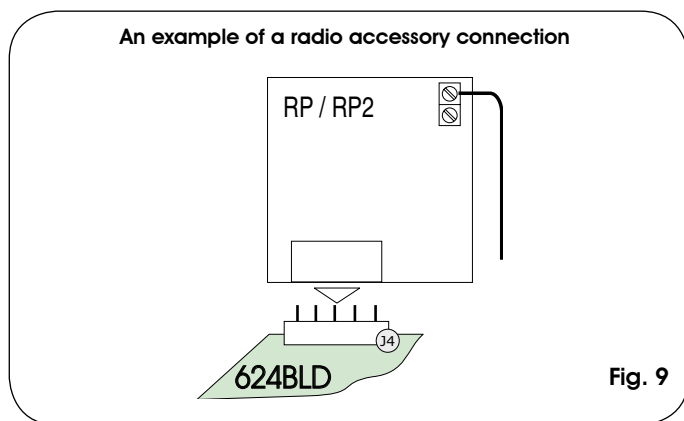



**5. PROGRAMMING**

To program the operation of the automated system, you must access the "PROGRAMMING" mode.

Programming is in three parts: 1st LEVEL, 2nd LEVEL and 3rd LEVEL.

 modification of the programming parameters is immediately effective, whereas definitive memory-storage occurs only on exiting programming and returning to the view of the automation status. If you cut power to the unit before returning to view the status, all the modifications made will be lost.

 You can return to viewing the status from any point of programming at any level, by pressing keys **F** and **-** simultaneously.

 To restore the programming default settings, simultaneously press keys **+**, **-** and **F** and hold them down for 5 seconds.

**5.1. 1<sup>ST</sup> LEVEL PROGRAMMING**

To access 1<sup>ST</sup> LEVEL PROGRAMMING, use push-button **F**:

- if you press it (and hold it down), the display shows the name of the first function.
- if you release the push-button, the display shows the value of the function, which can be changed with keys **+** and **-**.

- if you press **F** again (and hold it down), the display shows the name of the next function, etc.
- when you reach the last function, press the **F** push-button to exit programming, and the display resumes showing the inputs status.

The following table indicates the sequence of functions accessible in 1<sup>ST</sup> LEVEL PROGRAMMING:

1 <sup>ST</sup> LEVEL PROGRAMMING 		Default
Display	Function	Default
<b>df</b>	<b>LOADING PARAMETERS:</b> <b>00</b> Neutral condition <b>01</b> Default FAAC 1 loaded <b>02</b> Default FAAC 2 loaded <b>03</b> Default FAAC CITY loaded <b>04</b> Default FAAC CITY K loaded For an explanation of the <b>df</b> parameter, refer to <b>page 10 chapter 5.5</b> .	<b>00</b>
<b>LO</b>	<b>FUNCTION LOGICS:</b> <b>A</b> Automatic <b>AI</b> Automatic 1 <b>E</b> Semi-automatic <b>P</b> Parking <b>PA</b> Parking Automatic <b>CA</b> Condo <b>CA</b> Condo Automatic <b>rb</b> Faac-City (traffic bollard logic) <b>C</b> Dead-man <b>r</b> Remote <b>Cu</b> Custom	<b>E</b>
<b>PA</b>	<b>PAUSE TIME:</b> This operates only if an automatic logic was selected. Can be adjusted from <b>0</b> to <b>59</b> in one second steps. Next, the viewing changes in minutes and tenths of a second (separated by a dot) and time is adjusted in 10 second steps, up to the maximum value of <b>4.1</b> minutes. E.g. if the display shows <b>2.5</b> , the pause time will be 2 min and 50 sec.	<b>20</b>
<b>FO</b>	<b>POWER:</b> adjusts motor power. <b>01</b> = minimum power <b>50</b> = maximum power	<b>50</b>
<b>L1</b>	<b>LOOP 1:</b> If this function is activated, the loop connected to the Loop1 input will have the OPEN function. <b>Y</b> = loop1 active <b>no</b> = loop1 not active <b>Attention:</b> if the function is not activated, loop1 status will nevertheless be available on one of the outputs, if appropriately set (see second level programming).	<b>no</b>

Display	Function	Default
L2	<b>LOOP 2:</b> If you activate this function, the loop connected to Loop2 input will have the SAFETY /CLOSE function, i.e. it will operate as SAFETY during the closing stage, and will command CLOSE to the board at release. y = loop2 active no = loop2 not active <b>Attention:</b> if the function is not activated, loop2 status will nevertheless be available on one of the outputs, if appropriately set.	no
S1	NO EFFECT	05
S2	NO EFFECT	05
St	<b>AUTOMATED SYSTEM STATUS:</b> Exit from programming, storage of set data and return to automated system status view. 00 Closed 01 Opening pre-flashing 02 Opening 03 Open 04 On pause 05 Closing pre-flashing 06 Closing 07 Stopped ready to close 08 Stopped ready to open 09 Emergency opening 10 Closing safety device in operation	

**5.2. 2<sup>nd</sup> LEVEL PROGRAMMING**

To access 2<sup>nd</sup> LEVEL PROGRAMMING, press push-button **F** and, while holding it down, press push-button **+**.

- if you release the push-button **+**, the display shows the name of the first function.
- if you also release the **F** push-button, the display shows the value of the function, which can be changed with keys **+** and **-**.
- if you press the **F** key (and hold it down), the display shows the name of the next function; if you release it, the value is shown and can be modified with keys **+** and **-**.
- when you reach the last function, press the **F** push-button to exit programming, and the display resumes showing the inputs status.

The following table indicates the sequence of functions accessible in 2<sup>nd</sup> LEVEL PROGRAMMING:

2 <sup>nd</sup> LEVEL PROGRAMMING		
Display	Function	Default
bo	<b>MAXIMUM TORQUE AT THRUST:</b> the motor works at maximum torque (ignoring the torque adjustment) during the initial time of the movement. y = Active no = Excluded	y
PF	<b>PRE-FLASHING:</b> to activate the flashing light for 5 sec before the start of the movement no excluded OC before every movement PA at end of pause only CL before closing	no

Display	Function	Default
SC	<b>SLOW CLOSING:</b> for setting the entire closing stage at slow speed. y = Active no = Excluded	no
tr	<b>DECELERATION TIME AFTER LIMIT-SWITCHES:</b> for setting deceleration time (in seconds) after the opening and closing limit-switches have operated. Can be adjusted from 0 to 10 sec. in one second steps. 00 = deceleration excluded 10 = maximum deceleration	03
t	<b>WORK TIME (time-out):</b> We advise you to set a value from 5 to 10 seconds longer than the required by the automated system to move from the closing to the opening position and vice versa. Can be adjusted from 0 to 59 sec. in one second steps. Next, the viewing changes in minutes and tenths of a second (separated by a dot) and time is adjusted in 10 second steps, up to the maximum value of 41 minutes.	20
FS	<b>FAIL SAFE:</b> If this function is activated, it enables a function test of the photocells before any automated system movement, independently from the output used . If the test fails , the automated system does not start the movement. y = Active no = Excluded	no
o1	<b>OUTPUT 1:</b> The output can be set to one of the following functions: 00 FAILSAFE 01 INDICATOR LIGHT (lighted at opening and pause, flashing at closing, and off when automated system closed) 02 BEAMLIGHTING (output active with beam closed and on pause, inactive with beam open, flashing during movement) 03 Beam CLOSED 04 Beam OPEN or in PAUSE, it goes OFF during closing pre-flashing. 05 Beam MOVING AT OPENING, pre-flashing included. 06 Beam MOVING AT CLOSING, pre-flashing included. 07 Beam STILL 08 Beam in EMERGENCY status 09 LOOP1 engaged 10 LOOP2 engaged 11 OPEN for 624 SLAVE 12 CLOSE for 624 SLAVE 13 Beam DETACHED 14 FAAC - CITY lights 15 FAAC - CITY buzzer 16 FCA engaged 17 FCC engaged 18 interlock	00
P1	<b>OUTPUT 1 POLARITY:</b> for configuring the output polarity status. y = N.C. polarity no = N.O. polarity <b>Note:</b> if the output is set to FAIL-SAFE (00) leave the default value.	no
o2	<b>OUTPUT 2:</b> See output 1	03
P2	<b>OUTPUT 2 POLARITY:</b> See output 1 polarity	no
o3	<b>OUTPUT 3:</b> See output 1	01
P3	<b>OUTPUT 3 POLARITY:</b> See output 1 polarity	no



Display	Function	Default
04	<b>OUTPUT 4:</b> See output 1, except to functions 00, 11, 12 that in this case have not effect.	02
P4	<b>OUTPUT 4 POLARITY:</b> for configuring the output polarity status. y = N.C. polarity no = N.O. polarity	no
AS	<b>ASSISTANCE REQUEST (coupled to the next two functions):</b> If activated at the end of the count-down (settable with the next two functions under "Cycle programming"), it activates LAMP output for 4 sec every 30 sec. (assistance request). Can be useful for setting scheduled maintenance y = Active no = Excluded	no
nC	<b>CYCLE PROGRAMMING IN THOUSANDS:</b> For setting a count-down of the system operating cycles. Settable value from 0 to 99 (thousands of cycles). The displayed value is reset as the cycles progress, interacting with the nC value (99 nC decrementing steps correspond to one nC decrement). The function can be used combined with nC, to check the use of the system and to make use of the "Assistance request".	00
nC	<b>CYCLE PROGRAMMING IN HUNDREDS OF THOUSANDS:</b> For setting a count-down of the system operating cycles. Settable value from 0 to 99 (hundreds of thousands of cycles). The displayed value is reset as the cycles progress, interacting with the nC value (1 decrement of nC corresponds to 99 decrements of nC). The function can be used combined with nC to check the use of the system and to make use of the "Assistance request".	01
h1	<b>NO EFFECT</b>	00
h2	<b>NO EFFECT</b>	00
St	<b>AUTOMATED SYSTEM STATUS:</b> Exit from programming, storage of data and return to gate status view (see par. 5.1.).	

### 5.3. 3<sup>rd</sup> LEVEL PROGRAMMING

To access 3<sup>rd</sup> LEVEL PROGRAMMING, press push-button **F** and, while holding it down, press push-button **+** for about 10 seconds:

- if you release the push-button **+**, the display shows the name of the first function.
- if you also release the push-button **F**, the display shows the value of the function, which can be changed with keys **+** and **-**.
- if you press the push-button **F** (and hold it down), the display shows the name of the next function; if you release it, the values is shown and can be modified with keys **+** and **-**.
- when you reach the last function, press the push-button **F** to exit programming, and the display resumes showing the inputs status.

The following table indicates the sequence of functions accessible in 3<sup>rd</sup> LEVEL PROGRAMMING:

3 <sup>rd</sup> LEVEL PROGRAMMING  +  10sec		
Display	Function	Default / setting
01	If you enable this function, automatic closure occurs after pause time..	y = automatic closure no = disables
02	If you enable this function, operation is with two different inputs: OPEN for opening and CLOSE for closing	y = operation on two inputs no = disables
03	Activation of recognition of input levels OPEN and CLOSE (command maintained), i.e. the board recognises the level (e.g. with OPEN maintained and STOP pressed, when the latter is released, the automated system continues to open). If 03 is disabled, the board commands a manoeuvre only if the input is varied.	y = recognition of input level no = recognition of input variation
04	Activation of DEAD MAN opening (command always pressed). If the OPEN command is released, operation is stopped.	y = enables no = disables
05	If you enable this function, an OPEN command during opening stops the movement. If parameter 06 is no the system is ready for opening If parameter 06 is y the system is ready for closing	y = OPEN at opening stops movement no = disables
06	If you enable this function, an OPEN command during opening reverses movement. If parameters 05 and 06 are no, OPEN has no effect during opening	y = OPEN at opening reverses no = disables
07	If you enable this function, an OPEN command during the pause stops operation If parameters 07 and 08 are no, OPEN recharges pause time	y = OPEN during pause stops movement no = disables
08	If you enable this function, an OPEN command during the pause causes closure If parameters 07 and 08 are no, OPEN recharges pause time.	y = OPEN in pause closes no = disables
09	If you enable this function, an OPEN command during closure, stops operation, otherwise it reverses movement.	y = stops movement no = reverses
10	DEAD MAN closing enabled (command always pressed). If you release the CLOSE command, operation is stopped.	y = enables no = disables
11	If you enable this function, a CLOSE command has priority over OPEN, otherwise OPEN has priority over CLOSE.	y = enables no = disables
12	If you enable this function, a CLOSE command commands closure when it is released. Until CLOSE is enabled, the unit remains in closure pre-flashing.	y = CLOSE closes when released no = CLOSE closes at once
13	If you enable this function, a CLOSE command during opening stops operation, otherwise the CLOSE command commands reversing immediately or at end of opening (also see parameter 14)	y = CLOSE stops movement no = CLOSE reverses
14	If you enable this function, and if parameter 13 is no, the CLOSE command commands immediate closure at end of opening cycle (memory stores CLOSE) If parameters 13 and 14 are no, CLOSE commands immediate closure.	y = immediate closure at end of opening no = immediate closure
15	If you enable this function, when the system is stopped by a STOP a subsequent OPEN command moves in the opposite direction. If parameter 15 is no it always closes.	y = OPEN moves in opposite direction no = OPEN always closes
16	If you enable this function, during closing, the CLOSING SAFETY DEVICES stop movement and allow resumption of movement when disengaged, otherwise they immediately reverse at opening.	y = closure at disengagement no = immediate reversing



Display	Function	Default / setting
17	If you enable this function, the CLOSING SAFETY DEVICES command closure when disengaged (also see parameter 18).	y = closure when FSW disengaged no = disables
18	If you enable this function, and if parameter 17 is y, the unit waits for the opening cycle to end before executing the closing command supplied by the CLOSING SAFETY DEVICES.	y = closing at end of opening no = disables
19	If you enable this function, during closing, LOOP2 stops movement and allows it to resume at disengagement, otherwise it immediately reverses at opening.	y = closure at disengagement no = immediate reversing
20	If you enable this function, LOOP2 commands closing when disengaged (also see parameter 21).	y = closure when LOOP2 disengaged no = disables
21	If you enable this function, and if parameter 20 is y, the unit waits for the opening cycle to end before executing the closing command supplied by LOOP2.	y = closure at end of opening no = disables
22	<b>NOT USED</b>	/
23	LOOP 1 commands opening and, at end of opening, closes if released (useful if a vehicle reverses with consecutive loops). If disabled at release of LOOP 1, no closure is performed.	y = closure at release of LOOP1 no = disables
24	<b>NOT USED</b>	/
25	<b>A.D.M.A.P. function</b> If you enable this function, the safety devices operate according to French standards: in closed status, the CLOSING SAFETY DEVICES prevent opening. The unit memory stores OPEN and opens when the CLOSING SAFETY DEVICES are disengaged.	y = enables no = disables
26	If you enable this function, during closure, the CLOSING SAFETY DEVICES stop movement and, when disengaged, reverse movement, otherwise they reverse immediately.	y = stops movement and reverses when disengaged no = reverses immediately
27	<b>NO EFFECT</b>	/
A1	<b>PRE-FLASHING</b> Used for adjusting - in 1 sec steps - the duration of required pre-flashing, from a minimum of 0 to a maximum of 10 seconds	05
A2	<b>TIMEOUT FOR REVERSING AT CLOSURE:</b> If you enable this function, during closing, you can decide whether to reverse or stop the movement when time out elapses (closing stroke limit not reached). y = reversing no = stop	no
A3	<b>OPENING AT POWER UP</b> In case of a power cut, when power is restored, an opening operation can be commanded by enabling this function (only if the automated system is not closed, FCC free). y = opening no = stays still	no
A4	<b>CLOSING SAFETY DEVICES ENABLEMENT TIME:</b> The time after which the unit ignores enablement of the CLOSING SAFETY DEVICES, continuing to close (useful for use with the pressure switch of FAAC CITY). Can be adjusted from 0 to 59 sec. in 1 second steps. Subsequently, the display changes to show minutes and tenths of a second (separated by a dot), up to a maximum value of 4.1 minutes.	4.0
A5	<b>DISABLING CLOSING SAFETY DEVICES AT START OF MOVEMENT:</b> The CLOSING SAFETY DEVICES can be disabled at start of the closing operation (useful for use with the FAAC CITY pressure switch).	no
A6	<b>FAAC CITY SOLENOID VALVE CONTROL:</b> y = FAAC CITY K no = FAAC CITY standard	no

Display	Function	Default / setting
A7	<b>POLARITY OF OPENING TRAVEL-LIMIT STOP:</b> Configuration of the travel-limit stop contact y = polarity NO no = polarity NC	no
A8	<b>POLARITY OF CLOSING TRAVEL-LIMIT STOP:</b> Configuration of the travel-limit stop contact y = polarity NO no = polarity NC	no
A9	<b>FAAC CITY PRESSURE SWITCH ENABLED:</b> Recognition of PRESSURE SWITCH contact as a safety device and travel-limit stop for FAAC CITY: y = Operation for FAAC CITY no = Standard operation	no
b1	<b>SAFETY ONLY PRESSURE SWITCH FOR FAAC CITY:</b> Recognition of PHOTOCELL contact as a safety PRESSURE SWITCH but not as TL for FAAC CITY y = Operation with dedicated mechanical travel-limit stop and safety only pressure switch. no = Standard operation	no
b2	<b>DO NOT MODIFY</b>	30
St	<b>AUTOMATED SYSTEM STATUS:</b> Exit from programming, memory storage of data and return to gate status display (see par.5.1.).	

#### 5.4. MODIFICATION OF FUNCTION LOGIC

Procedure for implementing the modification of one or more 3rd level programming parameters,

1. Select one of the basic logics most suitable for your requirements.
2. Enter the 3rd programming level and modify the required parameters.
3. Exit the 3rd programming level, memory storing the modifications and, from the 1st level select logic Cu.

The Cu logic enables you to maintain all the settings you had made in 1st and 2nd level programming and enables the modifications made at 3rd level.

The following table contains the default parameters affecting the function logics.

Step	A	A1	E	P	PA	Cn	CA	rb	C
01	Y	Y	N	N	Y	N	Y	Y	N
02	N	N	N	Y	Y	Y	Y	Y	Y
03	N	N	N	N	N	N	N	Y	N
04	N	N	N	N	N	N	N	N	Y
05	N	N	Y	N	N	N	N	N	N
06	N	N	Y	N	N	N	N	N	N
07	N	N	N	N	N	N	N	N	N
08	N	N	N	N	N	N	N	N	N
09	N	N	N	N	N	N	N	N	N
10	N	N	N	N	N	N	N	N	Y
11	N	N	N	N	N	N	N	N	N
12	N	N	N	Y	Y	N	N	N	N
13	N	N	N	N	N	N	N	N	N
14	N	N	N	Y	Y	Y	Y	N	N
15	N	N	N	N	N	N	N	N	N
16	N	N	N	Y	Y	N	N	N	N
17	N	Y	N	N	N	N	N	N	N
18	N	Y	N	N	N	N	N	N	N
19	N	N	N	Y	Y	N	N	N	N
20	N	Y	N	Y	Y	Y	Y	N	N
21	N	Y	N	Y	Y	Y	Y	N	N
22	N	N	N	N	N	Y	Y	N	N
23	N	N	N	Y	Y	N	N	N	N
24	N	N	N	N	N	N	N	N	N

**5.5. MODIFICATION OF PRE-SETTING OF LOGICAL PARAMETERS**

The modification of **df** parameter enables to automatically load 4 different configurations modifying **all programming values on every level** with preset values.

This possibility is a starting point for subsequent 'fine tuning' of other parameters depending on the application and its context.

For example, if you choose **01** and exiting from 1st level programming, all the FAAC default values which can be found in tables of 1st, 2nd and 3rd level in the "Default" column are loaded.

In this way, all the parameters in the memory are returned to a known standard condition (see table under).

To implement the loading of the values of one of the 4 pre-settings, select the required number and exit 1st level programming.

**If you do not wish to load or modify a pre-setting, leave the **df** step on value **00**.**

The table below shows the main default values which are loaded on selecting each of the 4 pre-settings:

	Parameters	df=01	df=02	df=03	df=04
1 <sup>st</sup> level	L <sub>0</sub> logic	E	A1	rb	rb
	PA pause	20		30	30
	DF force	50			
	L1 loop 1	no			
	L2 loop 2	no			
	S1 not used	5			
	S2 not used	5			
	2 <sup>nd</sup> level	b <sub>0</sub> boost	4		
PF pre-flashing		no	CL		
SC slow closing		no			
t <sub>r</sub> slow-down		3			
t time out		20		12	12
F5 fail safe		no			
o1 output 1		00	16	15	15
P1 polarity 1		no			
o2 output 2		03	17	14	14
P2 polarity 2		no			
o3 output 3		01	01		
P3 polarity 3		no			
o4 output 4		02			
P4 polarity 4		no			
AS assistance		no			
n <sub>c</sub> cycles 1.		00			
n <sub>c</sub> cycles 2.		01			
h1 not used		no			
h2 not used		no			
3 <sup>rd</sup> level		25	no		
	26	no			
	27	no			
	A1	5	4		
	A2	no			
	A3	no			
	A4	4		4	4
	A5	no		4	4
	A6	no			4
	A7	no			
	A8	no			
	A9	no		4	4
b1	no				
b2	30				



**Attention: The selection of a default and subsequent exit from 1st level programming entails the deletion of all the modifications made previously.**

**Make sure that you carry out the required default loading and exit 1st level programming BEFORE modifying other steps.**

**6. START-UP**

**6.1. LEDS CHECK**

The following table shows the status of the LEDs in relation to the status of the inputs (the closed at rest automated system condition is shown in **bold**).

Check the status of the signalling LEDs as per table below:

Note that:

**LED ON** = closed contact

**LED OFF** = open contact

**Operation of status signalling LEDs**

LED	Description	ON (closed contact)	OFF (Open contact)
DL1	OPEN	Command enabled	<b>Command disabled</b>
DL2	CLOSE	Command enabled	<b>Command disabled</b>
DL3	FSW	<b>Safety devices released</b>	Safety devices engaged
DL4	STOP	<b>Command disabled</b>	Command enabled
DL5	EMERGENCY	<b>Command disabled</b>	Command enabled
DL6	FCA	<b>Opening limit switch free</b>	Opening limit switch engaged
DL7	FCC	Closing limit switch free	<b>Closing limit switch engaged</b>
DL8	PIVOT	<b>Beam attached</b>	Beam detached

**7. AUTOMATED SYSTEM TEST**

When you have finished programming, check if the system is operating correctly.

Above all, check if power is adequately adjusted and if the safety devices operate correctly.

Fig. 10

8. MASTER-SLAVE

624BLD  
MASTER

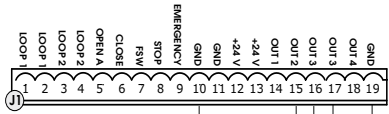

OUT2: a2 = 11 P2 = no  
OUT3: a3 = 12 P3 = no

624BLD  
SLAVE

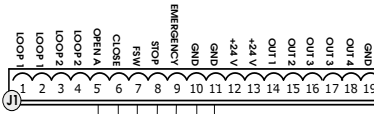

Logica  
Logic  
Logique  
Nur Logik  
Lógica  
De logica

LO = C

per il resto lasciare il default  
for the rest leave the default  
pour le reste laisser par défaut  
programmieren die anderen werkeinstellungen lassen  
por lo demas dejar el default  
voor de rest default laten

624 BLD  
MASTER

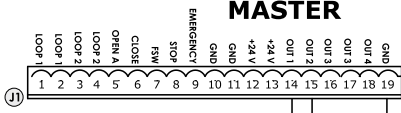

OUT2: a1 = 11 P1 = 4  
OUT3: a2 = 12 P2 = 4

624 MPS  
SLAVE

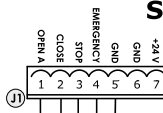

Logica  
Logic  
Logique  
Nur Logik  
Lógica  
De logica

R

per il resto lasciare il default  
for the rest leave the default  
pour le reste laisser par défaut  
programmieren die anderen werkeinstellungen lassen  
por lo demas dejar el default  
voor de rest default laten

624 MPS  
MASTER

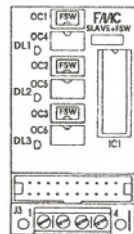
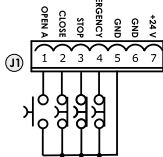

624 BLD  
SLAVE

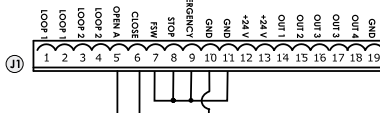

Logica  
Logic  
Logique  
Nur Logik  
Lógica  
De logica

LO = R

per il resto lasciare il default  
for the rest leave the default  
pour le reste laisser par défaut  
programmieren die anderen werkeinstellungen lassen  
por lo demas dejar el default  
voor de rest default laten

Fig. 10

LOGIC "A"	PULSES					
AUTOMATED SYSTEM STATUS	OPEN A	CLOSE	STOP	FSW	LOOP 1	LOOP 2
CLOSED	opens and closes after pause time	no effect	no effect (opening disabled)	no effect	opens and closes after pause time	no effect
OPENING	no effect	reverses immediately at closing	stops operation	no effect	no effect	no effect
OPEN IN PAUSE	recharges pause time	closes	stops operation	recharges pause time (closing disabled)	recharges pause time	recharges pause time (closing disabled)
CLOSING	reverses immediately at opening	no effect	stops operation	reverses immediately at opening	reverses immediately at opening	reverses immediately at opening
STOPPED	closes	closes	no effect (opening and closing disabled)	no effect (closing disabled)	opens and closes after pause time	no effect (closing disabled)

Tab. 1/b

LOGIC "A1"	PULSES					
AUTOMATED SYSTEM STATUS	OPEN A	CLOSE	STOP	FSW	LOOP 1	LOOP 2
CLOSED	opens and closes after pause time	no effect	no effect (opening disabled)	no effect	opens and closes after pause time	no effect
OPENING	no effect	reverses immediately at closing	stops operation	closes immediately at end of opening	no effect	closes immediately at end of opening
OPEN IN PAUSE	recharges pause time	closes	stops operation	closes	recharges pause time	closes
CLOSING	reverses immediately at opening	no effect	stops operation	reverses immediately at opening	reverses immediately at opening	reverses immediately at opening, closes when opening finished
STOPPED	closes	closes	no effect (opening and closing disabled)	no effect (closing disabled)	opens and closes after pause time	no effect (closing disabled)

Tab. 1/c

LOGIC "E"	PULSES					
AUTOMATED SYSTEM STATUS	OPEN A	CLOSE	STOP	FSW	LOOP 1	LOOP 2
CLOSED	opens	no effect	no effect (opening disabled)	no effect	opens	no effect
OPENING	stops operation	reverses immediately at closing	stops operation	no effect	no effect	no effect
OPEN	closes	closes	no effect (closing disabled)	no effect (closing disabled)	closes	no effect (closing disabled)
CLOSING	reverses immediately at opening	no effect	stops operation	reverses immediately at opening	reverses immediately at opening	reverses immediately at opening
STOPPED	closes	closes	no effect (opening and closing disabled)	no effect (closing disabled)	opens	no effect (closing disabled)

↻ In brackets: effects on the other inputs when pulse active

Tab. 1/d

LOGIC "P"	PULSES					
AUTOMATED SYSTEM STATUS	OPEN A	CLOSE	STOP	FSW	LOOP 1	LOOP 2
CLOSED	opens	no effect	no effect (opening disabled)	no effect	opens and at end of opening closes if disengaged	no effect
OPENING	no effect	closes immediately at end of opening	stops operation	no effect	no effect	closes immediately at end of opening
OPEN	no effect (closing disabled)	closes	no effect (closing disabled)	no effect (closing disabled)	no effect	closes
CLOSING	reverses immediately at opening	no effect	stops operation	stops and continues to close on release	reverses immediately at opening and closes at end of opening if disengaged	stops and continues to close on release
STOPPED	opens	closes	no effect (opening and closing disabled)	no effect (closing disabled)	opens and at end of opening closes if disengaged	no effect (closing disabled)

ENGLISH

Tab. 1/e

LOGIC "PA"	PULSES					
AUTOMATED SYSTEM STATUS	OPEN A	CLOSE	STOP	FSW	LOOP 1	LOOP 2
CLOSED	opens and closes after pause time	no effect	no effect (opening disabled)	no effect	opens and at end of opening closes if disengaged	no effect
OPENING	no effect	closes immediately at end of opening	stops operation	no effect	no effect	closes immediately at end of opening
OPEN IN PAUSE	recharges pause time	closes	stops operation	recharges pause time (closing disabled)	recharges pause time	closes
CLOSING	reverses immediately at opening	no effect	stops operation	stops and continues to close on release	reverses immediately at opening and closes at end of opening if disengaged	stops and continues to close on release
STOPPED	opens and closes after pause time	closes	no effect (opening and closing disabled)	no effect (closing disabled)	opens and at end of opening closes if disengaged	no effect (closing disabled)

Tab. 1/f

LOGIC "Cn"	PULSES					
AUTOMATED SYSTEM STATUS	OPEN A	CLOSE	STOP	FSW	LOOP 1	LOOP 2
CLOSED	opens	no effect	no effect (opening disabled)	no effect	opens	no effect
OPENING	no effect	closes immediately at end of opening	stops operation	no effect	no effect	closes immediately at end of opening
OPEN	no effect (closing disabled)	closes	no effect (closing disabled)	no effect (closing disabled)	no effect	closes
CLOSING	reverses immediately at opening	no effect	stops operation	reverses immediately at opening	reverses immediately at opening	reverses immediately at opening
STOPPED	opens	closes	no effect (opening and closing disabled)	no effect (closing disabled)	opens	no effect (closing disabled)

↻ In brackets: effects on the other inputs when pulse active

Tab. 1/g

LOGIC "CA"	PULSES					
AUTOMATED SYSTEM STATUS	OPEN A	CLOSE	STOP	FSW	LOOP 1	LOOP 2
CLOSED	opens and closes after pause time	no effect	no effect (opening disabled)	no effect	opens and closes after pause time	no effect
OPENING	no effect	closes immediately at end of opening	stops operation	no effect	no effect	closes immediately at end of opening
OPEN IN PAUSE	recharges pause time	closes	stops operation	recharges pause time (closing disabled)	recharges pause time	closes
CLOSING	reverses immediately at opening	no effect	stops operation	reverses immediately at opening	reverses immediately at opening	reverses immediately at opening
STOPPED	opens and closes after pause time	closes	no effect (opening and closing disabled)	no effect (closing disabled)	opens and closes after pause time	no effect (closing disabled)

Tab. 1/h

LOGIC "tb"	PULSES					
AUTOMATED SYSTEM STATUS	OPEN A	CLOSE	STOP	FSW	LOOP 1	LOOP 2
CLOSED	opens and closes after pause time	no effect	no effect (opening disabled)	no effect	opens and closes after pause time	no effect
OPENING	no effect	reverses immediately at closing	stops operation	no effect	no effect	no effect
OPEN IN PAUSE	recharges pause time	closes	stops operation	recharges pause time (closing disabled)	recharges pause time	recharges pause time (closing disabled)
CLOSING	reverses immediately at opening	no effect	stops operation	reverses immediately at opening	reverses immediately at opening	reverses immediately at opening
STOPPED	opens and closes after pause time	closes	no effect (opening and closing disabled)	no effect (closing disabled)	opens	no effect (closing disabled)

Tab. 1/i

LOGIC "C"	MAINTAINED COMMANDS		PULSES			
AUTOMATED SYSTEM STATUS	OPEN A	CLOSE	STOP	FSW	LOOP 1	LOOP 2
CLOSED	opens	no effect	no effect (opening disabled)	no effect	no effect	no effect
OPENING	/	no effect	stops operation	no effect	no effect	no effect
OPEN	no effect (closing disabled)	closes	stops operation	no effect	no effect (closing disabled)	no effect (closing disabled)
CLOSING	reverses immediately at opening	/	stops operation	Stops operation	stops operation	stops operation
STOPPED	opens	closes	no effect (opening and closing disabled)	no effect (closing disabled)	no effect (closing inhibited)	no effect (closing disabled)

↻ In brackets: effects on the other inputs when pulse active